



Humidity Sensor

Model. C7-M62

The SHINYEI HUMENT Type HPR-MQ is a humidity device formed by distributing a humidity sensitive macro-molecule onto an electrode substrate. The resistance of the device varies exponentially with variation on relative humidity.

Feature	Application
Wide humidity operating range	Air-conditioner, Humidifier, Dehumidifier
Outstanding repeatability	Humidity Controller, Humidity Transmitter
Long-term stability	Hygrometer, Hygro-recorder
Low hysteresis	Copying machine
Small and light-weight	Clock, Weather-forecast barometer

Characteristics

Model	C7-M62
Humidity Sensor element	Shinyei Hument HPR-MQ-M62
Rated Voltage	5 VAC (Max.)
Operating Temperature Range	-20 to 60deg. C
Operating Humidity Range	95%rh or less
Standard Humidity Resistance	50k Ohm (at 25deg. C, 60%rh, 1kHz)
Humidity Measurement Accuracy	+/-5%rh (at 25deg. C, 60%rh, 1kHz)
Material of Sensor Housing	ABS
Color of Sensor Housing	White
Dimension	10 x 27.5 x 5 mm (FC-7)

Configuration

Model :C7-M62

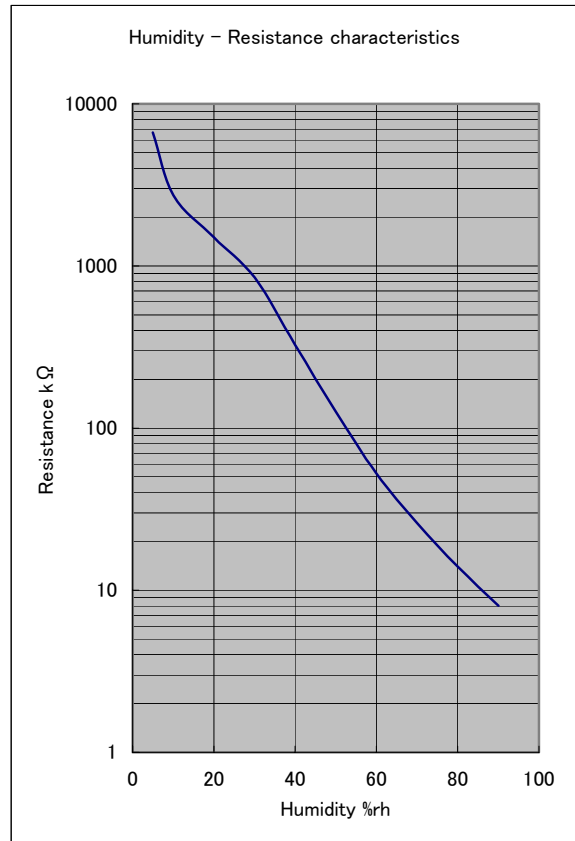
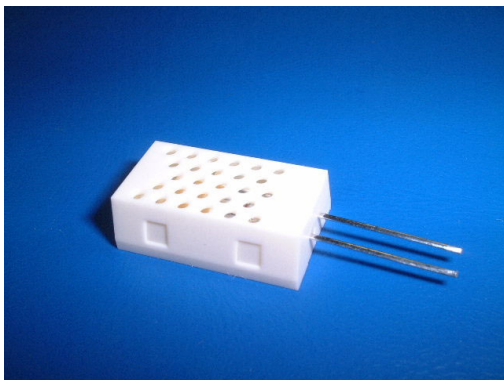
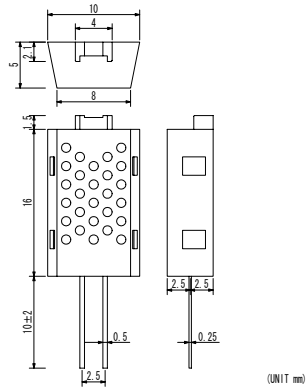

Remark; We have the right to revise specifications and product configurations without notice.

Caution for use



- ! Avoid condensation and drenching.
- ! Avoid application of the Humidity Sensor in the salt, inorganic gases and organic gases.



Contact :

Shinyei Corporation of America
 11 East 44th St., Ste.700, New York, NY 10017
 TEL (212)682-4610 FAX (212)286-8426
 E-mail: tony.tokuya@sca-shinyei.com